

Wire Balustrade Flat Mount - DIY Component Installation Advice

Each run of balustrade wire infill should comprise of the following components:

- 1 x 4mm Ø 7x7 stainless steel wire rope.
- 2 x Ball end sockets (1 for each end).
- 1 x Swageless ball end.
- 1 x Swageless ball end tensioner,
- 2 x Screw fixings for ball end sockets (1 for each socket).

Preparation :

Before installation we would recommend you consult with your local building control.

Plan your project in advance to ensure you have the correct number of posts, wires and fittings remembering to take into consideration end post and corner post termination clearance and position.

Stainless steel wire cables should be spaced a maximum of 100mm apart.

Vertical posts should be spaced at recommended 1.5 metre intervals (up to a max of 2 metres) to ensure a strong frame.

Note :

If mounting to masonry surfaces please drill a hole and insert a plastic plug before fastening. If a wall is particularly brittle or old - a chemical resin could be applied to strengthen the hold.

Tensioning Sequence :

To tension the balustrade wires, we recommend starting from the centre and working out.

Do not fully tighten individual wires as this will create uneven tension throughout your system, just tighten enough to hold in place.

Once all your wires are installed, tighten each wire in turn by slight increments to achieve a solid and fully secure finish.

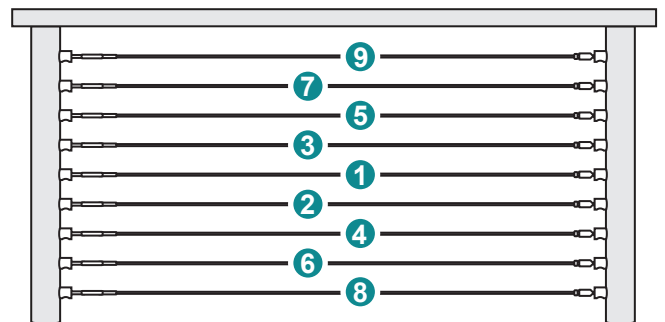

1 Getting Started

It is a good idea to layout your design onto the relevant surface with a pen or chalk prior to drilling any holes.



2 Drill Pilot Holes

The wood screws allow for direct installation into hardwood timber (such as oak) or, if combined with the correct plastic plug, it is attachable to almost any masonry surface.

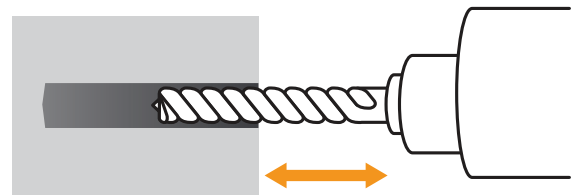

3 Mount Hubs into Position

Using a screwdriver fix the surface mounting hubs using the stainless steel wood thread screws.

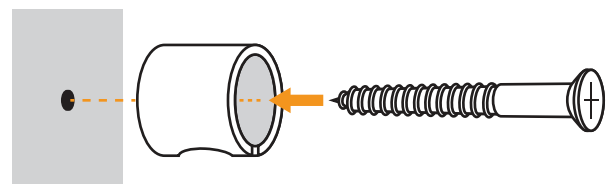

Tip : Position the opening facing downwards for a better final look.

Wire Balustrade Flat Mount - DIY Component Installation Advice

- 4 DIY Compression Fitting**
Take apart your DIY compression fitting by simply unscrewing the nose piece and remove the cone from inside.

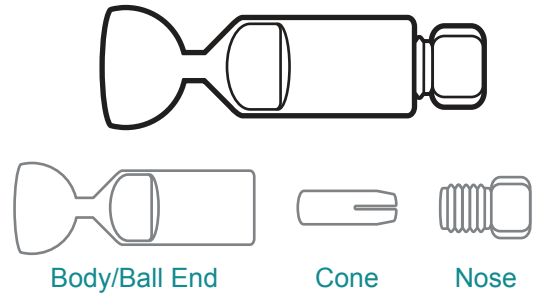

- 5 Thread Nose Piece onto Wire**
Taking the blank wire end place the nose piece over the stainless steel wire rope (ensuring the thread end is towards the end of your wire).



- 6 Thread Cone onto Wire**
Thread the cone onto the wire and push into the threaded cone chamber.

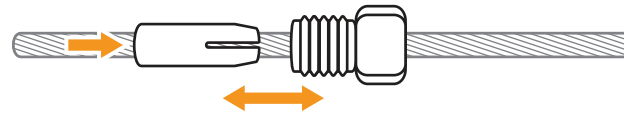

- 7 Place Ball End onto Wire**
Take the stainless steel body and push onto the wire, eventually bringing the three component parts together. Turn in opposite directions to thread them together.

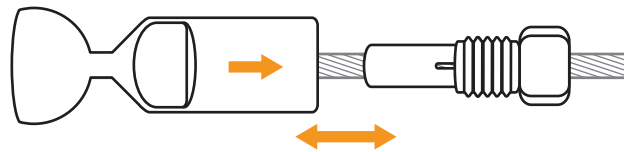

- 8 Secure Ball End Fitting**
Using a pair of 8mm and 9mm spanners screw the two sections together until tight.

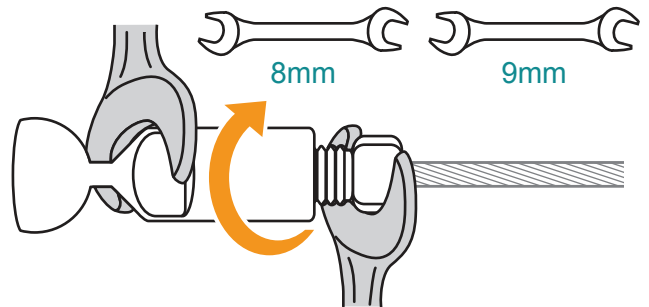

- 9 Mounting Ball End Fitting**
Insert the DIY ball end into the fixing hole of the hub.

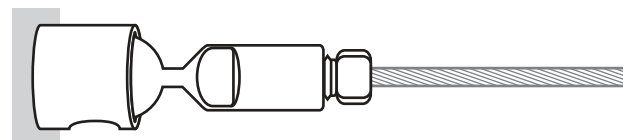
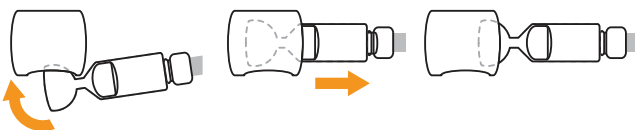

Tip:

Before fitting the Ball End Tensioner to your wire rope we recommend you have installed the fixed ball end fitting on to the opposite end of your wire rope, and the mounting sockets on to your posts. This will enable you to calculate the length of wire rope required before cutting.

Wire Balustrade Flat Mount - DIY Component Installation Advice

10 Prepare Ball End Tensioner

Screw out the ball end to reveal approximately 20mm of thread, you will need this to apply your final wire tension once installed.

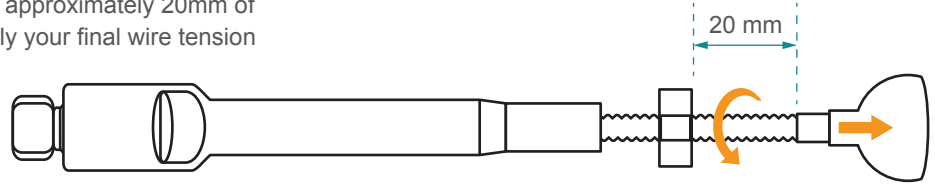

11 Mark Wire for Cutting

Insert ball end tensioner in to its mounting socket and pull the attached wire rope over from the other fixing post and align to the spanner flat of the DIY compression fitting.

Mark your wire ready for cutting with either a pen or chalk.

Note: The stand off from the mounting hub is 93mm when fully engaged.

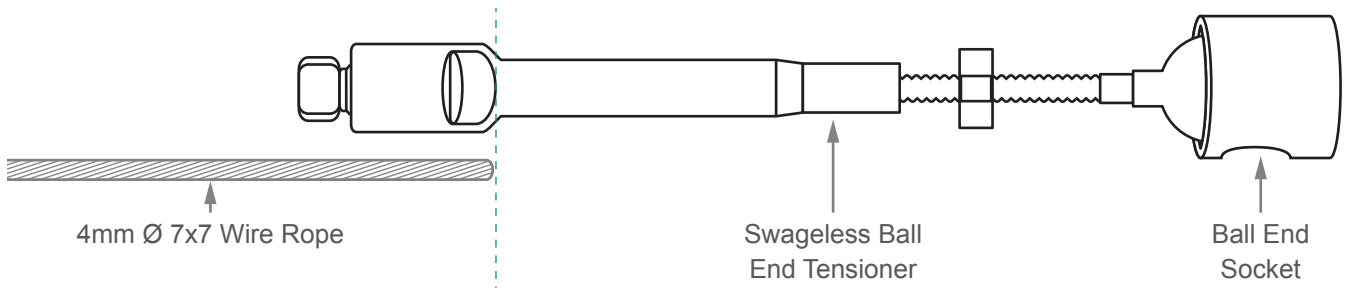

12 Cut Wire

Cut your wire to required length, we recommend using a set of good wire rope cutters to give you a neat and tidy cut.

Remember - Measure Twice, Cut Once!
Please be as accurate as possible.

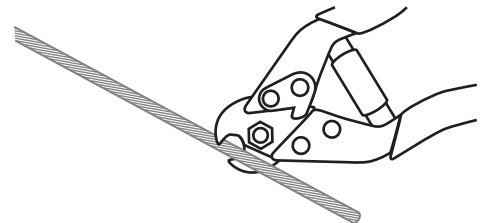

13 DIY Ball End Tensioner Compression Fitting

The method for attaching your wire rope to the ball end tensioner is the same as the fixed ball end, start by taking apart your DIY compression fitting by unscrewing the body from the nose piece to reveal the cone.

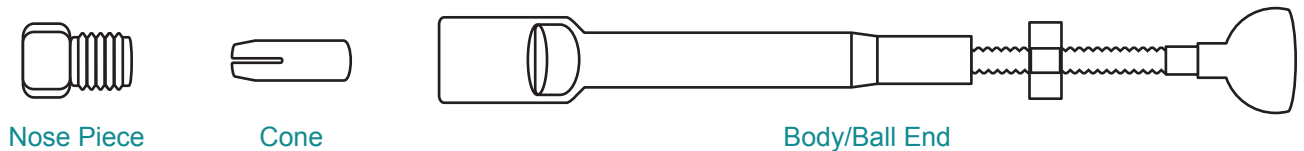

14 Thread Nose Piece onto Wire

Taking the blank wire end place the nose piece over the stainless steel wire rope (ensuring the thread end is towards the end of your wire).



15 Thread Cone onto Wire

Thread the cone onto the wire and push into the threaded cone chamber.

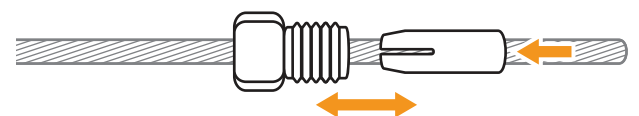

Wire Balustrade Flat Mount - DIY Component Installation Advice

16 Place Ball End onto Wire

Take the stainless steel body and push onto the wire, bringing the three component parts together. Turn in opposite directions to thread them together.

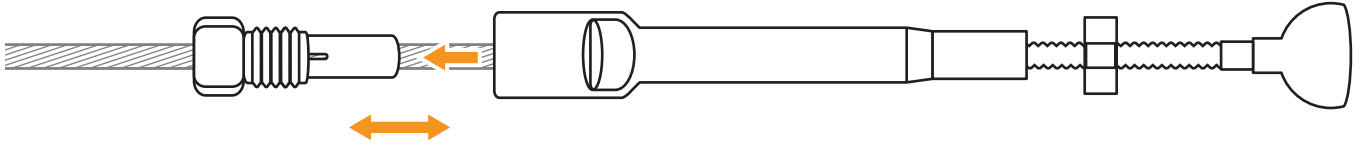

17 Secure Ball End Fitting

Using 8mm and 9mm spanners screw the two sections together until tight, the wire rope should be held firmly in place.

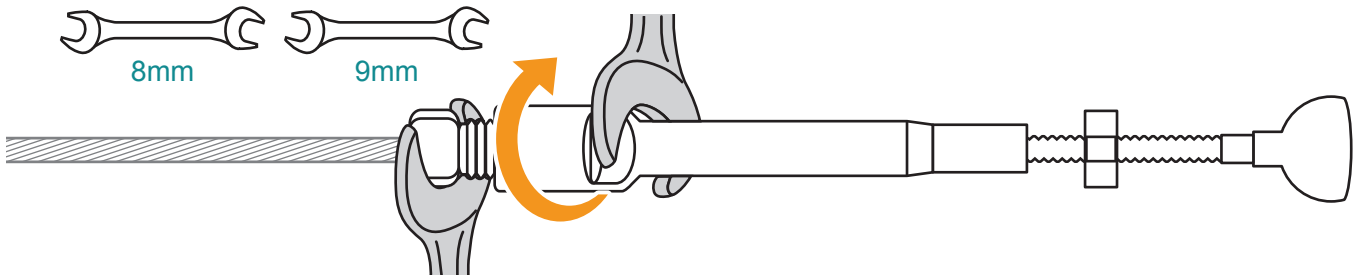

18 Tension Wire

Insert the DIY ball end into the fixing hole of the hub. Holding the tensioner body, use a 5mm spanner on the spanner flat just before the ball end to screw in the thread to tension wire rope.

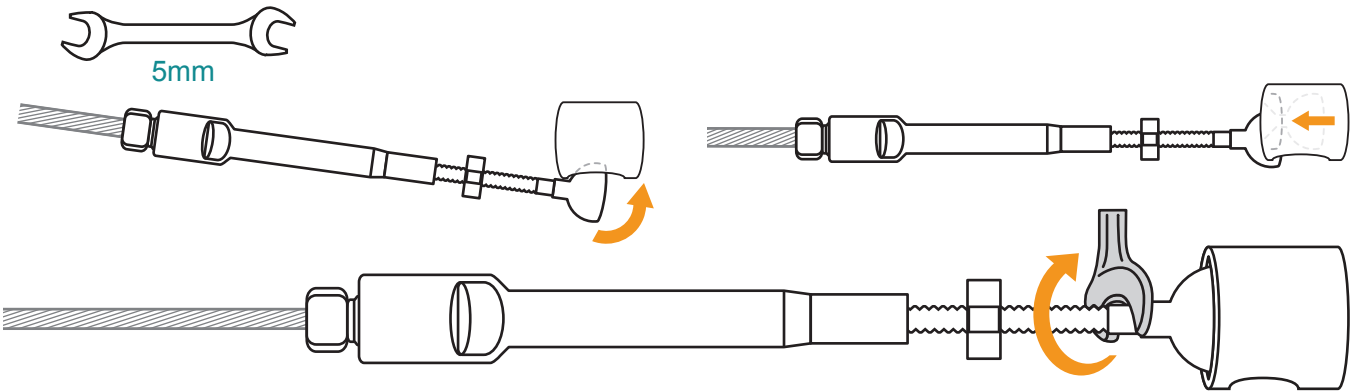

19 Lock in Place

Once tension is achieved simply hold the tensioner body and tighten the lock nut in place using a 10mm spanner.

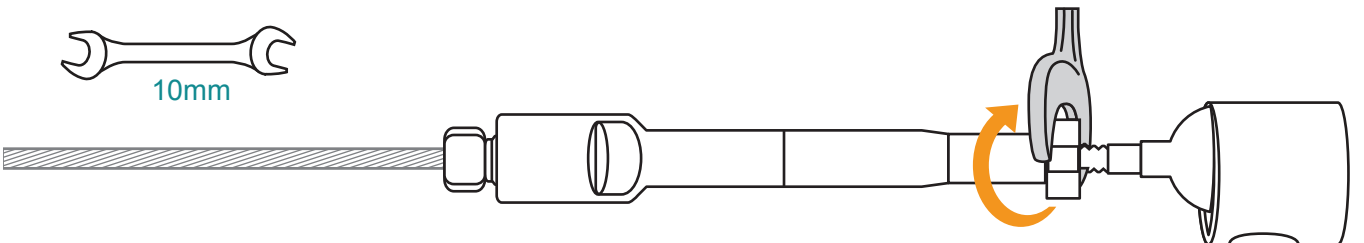

20 Check Wire tension

Once fully installed, we recommend double checking the wire tension, if needed adjust as required.