

## Fascia Mount - Easy Alu Balustrade Installation Advice

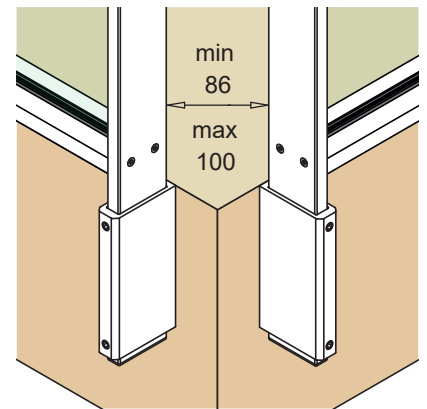
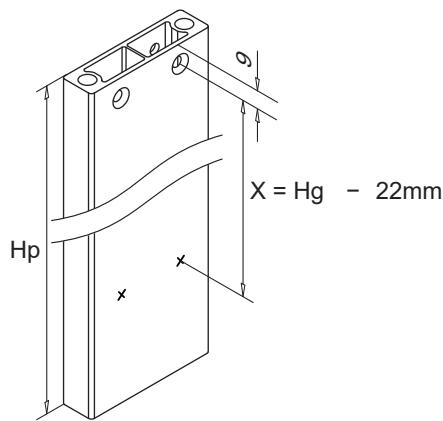
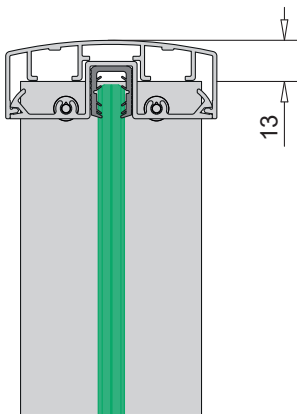
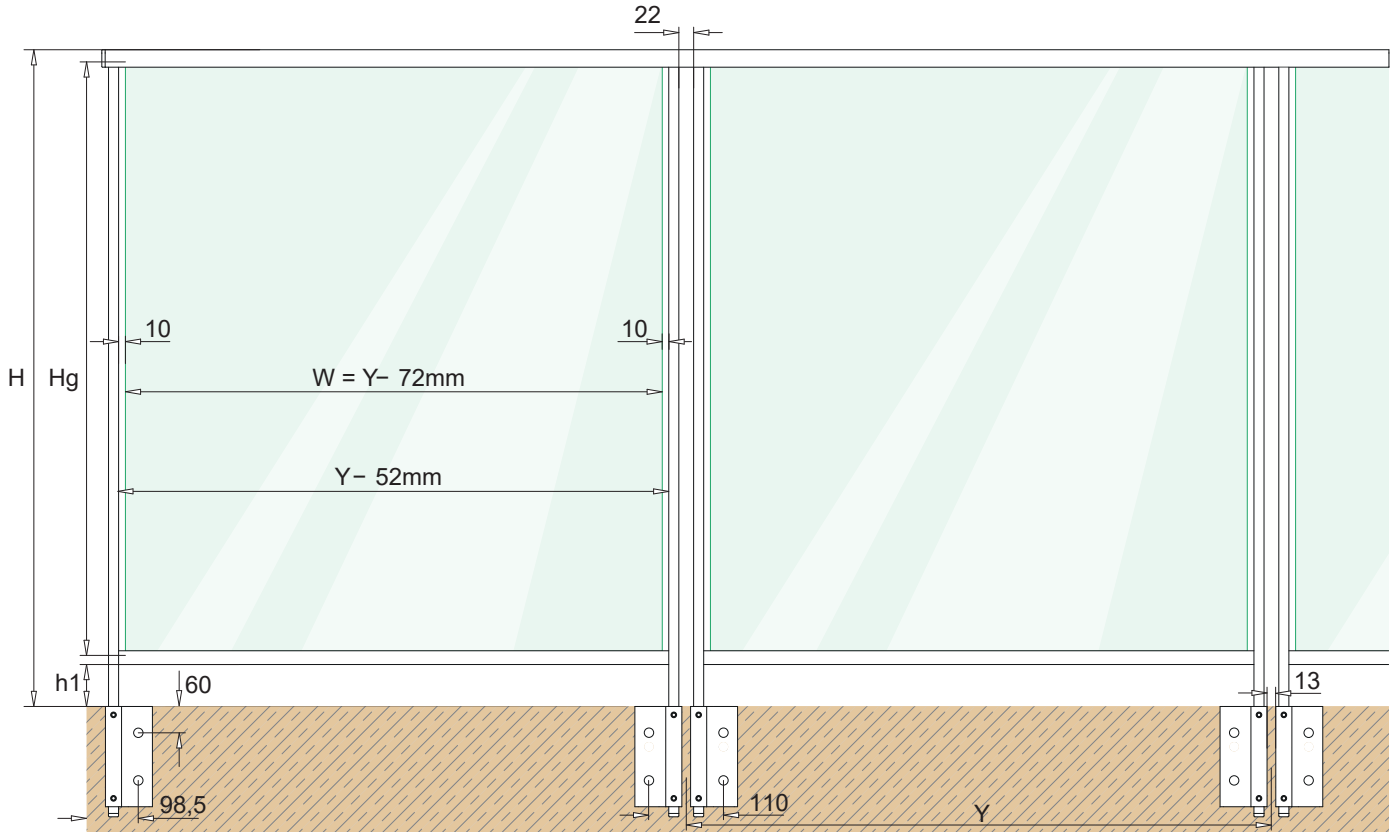

### Calculation baluster post

Railing height (H) + 140mm = baluster post height (Hp)

Railing height (H)	Baluster post height (Hp)
900mm	1040mm
1000mm	1140mm
1100mm	1240mm
1200mm	1340mm

### Glass calculation

Railing height (H)

Glass width (W) =  $Y - 72\text{mm}$

Glass height ( $H_g$ ) = railing height (H) -  $h_1$  -  $h_2$

### Distance drill holes in baluster post (X)

$X$  = glass height ( $H_g$ ) - 22mm

## Fascia Mount - Easy Alu Balustrade Installation Advice

