

Catenary Kit



Designed specifically for spanning installation and bracing applications

FEATURES / BENEFITS

- The light duty 3 mm version is ideal for suspending lightweight electrical services, ductwork and signage - up to 30 kg per free span
- The heavy duty 6 mm version is perfect for suspending M&E or HVAC services, or where a long catenary is required - up to 100 kg per free span
- Supplied as complete, ready-to-use kits, including galvanised wire rope
- Cut to bespoke lengths, hex locking key and release key included
- Fast installation, reducing time spent working at height
- Quarter turn locking
- Locking mechanism in the Gripple fastener prevents dynamic movements
- Easily tensioned using the Gripple Catenary Tensioning Tool



INSTALLATION & ADJUSTMENT

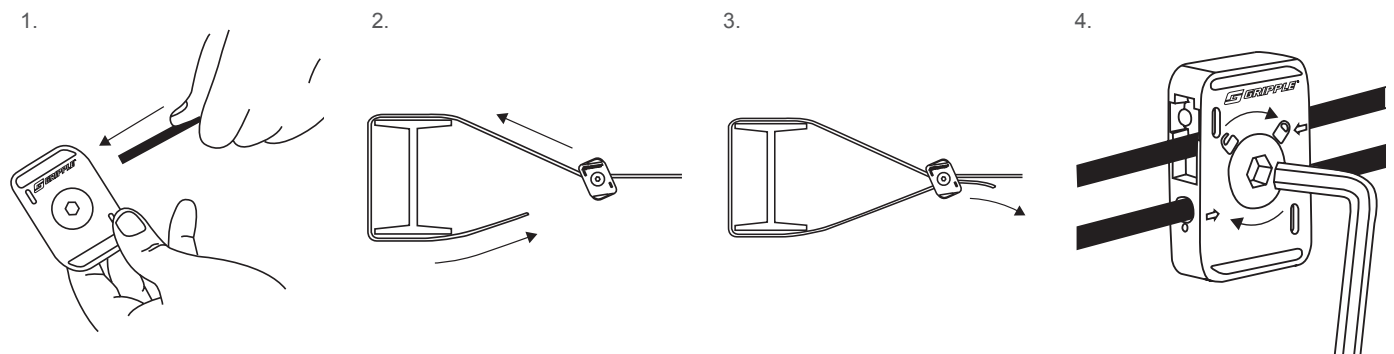

SPECIFICATION

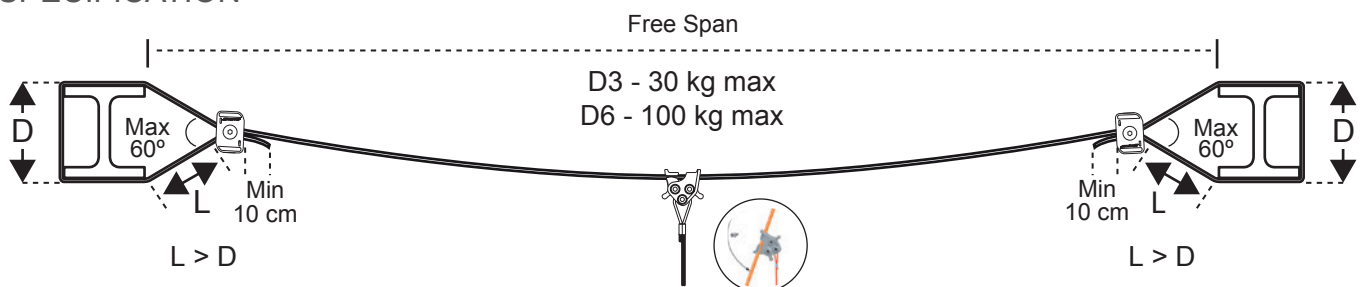

SUBMITTAL INFORMATION

Load Rating:

- D3 - up to 30 kg vertical load per free span
Connection type: 3 mm C-Clip
Not suitable for use with any Tensioning Tool
- D6 - up to 100 kg vertical load per free span
Connection type: 6 mm C-Clip
Can be used with the D6 Torq Tensioning Tool

Material:

Ceramic rollers and stainless springs for optimum corrosion resistance

Wire Rope Specifications:

- D3 - Galvanised 7 x 7, 3 mm or 1/8" steel wire rope
- D6 - Galvanised 7 x 19, 6 mm or 1/4" steel wire rope

AVAILABLE ACCESSORIES



Torq
Tensioning
Tool



3 mm
C-Clip



6 mm
C-Clip

For more options on available products please contact us or visit www.gripple.com